

PARÇA KODU PART CODE	PARÇA ADI PART NAME	s ÖLÇÜSÜ (KALINLIK) s MEASURE (THICKNESS)	Malzeme Material	Kaplama / Coating		
				SN	AG	Nİ
TŞ 2493 DP	1 NO 3.TERMİNAL Ø3.2 =DP=	0.50±0.05	(CuZn30) Pirinç / Brass	-	-	-
TŞ 2493 RP	1 NO 3.TERMİNAL Ø3.2 =RP=	0.50±0.05	(CuZn30) Pirinç / Brass	-	-	-
TŞ 2493 RPK	1 NO 3.TERMİNAL Ø3.2 =RPK=	0.50±0.05	(CuZn30) Pirinç / Brass	+	-	-
TŞ 2493 DPK	1 NO 3.TERMİNAL Ø3.2 =DPK=	0.50±0.05	(CuZn30) Pirinç / Brass	+	-	-

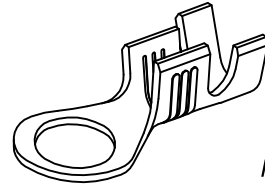
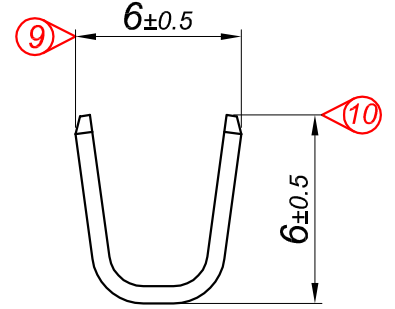
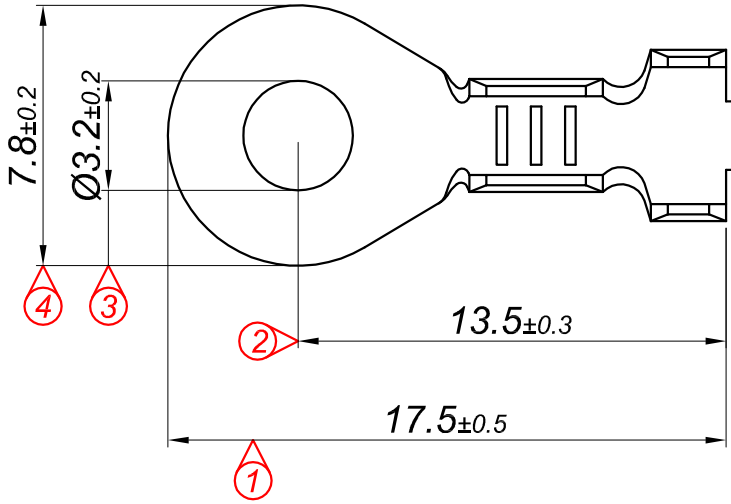
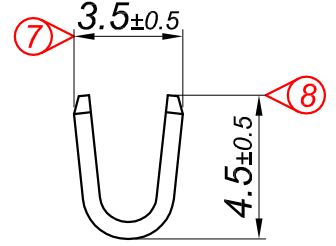
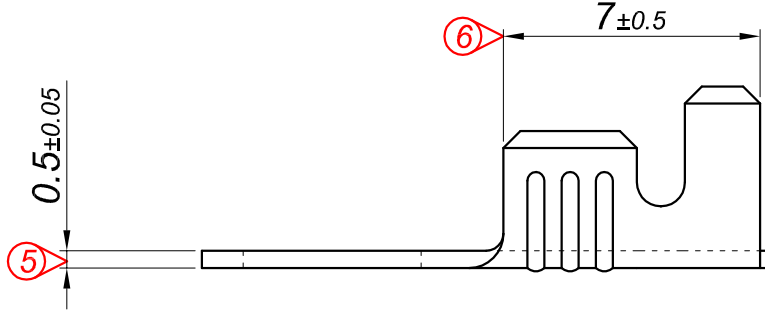

Perspektif
Perspective

Kalıp çıkış yönü
Mold output direction

Makara açılım yönü
Reel opening direction

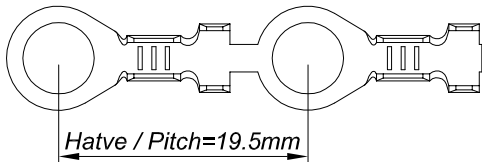

Ölçek
Scale : 3 / 1

Kablo Kesiti
Wire Section : 1 - 2.5 mm²

Resim üzerinden ölçü almayınız
do not measure on drawing

Tarih / Date	18.05.2016	İmza / Signature	Ölçek / Scale			
Çizen / Desing	T.Topçu					
Onay / Approval	S.Gölcük		5 / 1	No	Değişiklik / Revision	Tarih/Date



Parça Adı:
Part Name

1 NO 3.TERMİNAL Ø3.2

Parça Kodu:
Part Code

TŞ 2493